

# Data Transmission and Reception using Power Line Communication

S.Venkatesulu<sup>1</sup>, L.Hemasundar<sup>2</sup>, M.Sreeja<sup>3</sup>, K.Divya<sup>4</sup>, G.Jeevan Kumar<sup>5</sup>, M.Bhogendranadh<sup>6</sup>

<sup>#</sup> Associate Professor in Electronics and Communication Department Y.I.T.S Tirupathi,  
Andhra Pradesh, India

<sup>#</sup>Student of ECE YITS<sup>1, 2, 3, 4, 5, 6</sup>

<sup>1</sup>v.sugali7@gmail.com <sup>2</sup>lhemasundar@gmail.com <sup>3</sup>sreejamanchuri@gmail.com <sup>4</sup>divyasanjana.433@gmail.com

<sup>5</sup>amithewarrioroftheworld@gmail.com <sup>6</sup>bhoginani@gmail.com

**Abstract-** The novelties are presented in this paper a digital data transmission/reception via power lines. The Power line communications uses the existing power line infrastructure for communication purposes. This technology is preferred over other communication technologies like Satellite, Wireless and Optical fiber communications due to wide availabilities of power lines as Power lines are one of the most widely available communication medium for PLC technology and also it is already existing infrastructure. Finally we describe a communication strategy that eventually could be used for information transfer over the power-line communication channel. The advance power line communication system is to establish communication in remote area with High data rate and less cost.

**Index Terms-** Power Line Communication; ARIB; FCC; CENCELEC.

## 1. INTRODUCTION

Power Line Communications (PLC) is the use of existing electrical cables to transport data, and it has been around for a very long time. Power utilities have been using this technology for many years to send or receive data on the power grid using the existing infrastructure. For instance, the electrical power utility in London used PLC to remotely control some of its equipment on the grid (such as high-voltage switches) in the 1920s. This technique is still employed by several utilities that use analog or digital devices to transfer 9.6 Kbits/s over many miles of electrical cable. "Power Line Communications" basically means any technology that enables data transfer at narrow or broad band speeds through power lines by using advanced modulation technology. Our system will mostly be implemented in areas such as institutions, offices, etc. Power line communications can be used in office or home to

Interconnect home/office computers and peripherals, and home entertainment devices that have an Ethernet Port. Power line adapter sets plug into power outlets and establish an Ethernet connection using the existing electrical wiring in the home/office. (Power strips with filtering may absorb the power line signal.) This allows devices to share data without the inconvenience of running dedicated network cables. With just a simple set up of a transmitter and receiver, and ensuring equal phase supply, one can control a

host of devices and eliminates the need for additional cables.

The scope of this paper is to implement data communication using existing power lines in the vicinity with the help of KQ330F modules. The system basically consists of two modules, a transmitter and a receiver that can communicate with each other using the existing power cables.

## 2. HISTORY OF PLC

Power line communication has been around for quite some time, but has only been used for narrow band tele-remote relay applications, public lighting and home automation.

Broadband over PLC only began at the end of the 1990s:

- **1950:** at a frequency of 10Hz, 10kW of power, one-way: town lighting, relay remote control.
- **Mid 1980s:** beginning of research into the use of the electrical grid to support data transmission, on bands between 5 - 500Khz, always in a one-way direction,
- **1997:** first tests for bidirectional data signal transmission over the electrical supply

network and the beginning of research by Ascom (Switzerland) and Norweb (U.K.)

- **2000:** first tests carried out in France by EDF R&D and Ascom.

### 3. POWER LINE COMMUNICATION BANDS

The first generation PLC introduced operating in the band of 3-500 kHz. These technologies include the Federal Communication Commission (FCC) band in the U.S., the ARIB band in Japan, the Chinese band, and the CENELEC bands (3-148.5 kHz) in Europe. The CENELEC frequency range is divided into four sub -bands as follows:

- A band:* 3-95 kHz, for energy suppliers in the medium voltage networks;
- B band:* 95-125 kHz, available for low voltage consumers;
- C band:* 125-140 kHz;
- D band:* 140-148.5 kHz;

The next generation of PLC technology introduced was BB PLC with data rate up to 200 Mb/s, utilizing frequencies 1.5-30 MHz

Now a day, there is a growing interest in high-data-rate PLC technologies offering data rates up to 500 mb/s at the CENCELEC/FCC/ARIB bands.

#### 3.1. Power lines are classified into three types:

- *Short range:* 0-80km
- *Medium range:* 80-250km
- *Long range:* more than 250 km

### 4. TECHNOLOGY USED

In our system we use the KQ 330F Module. The advantages of using the KQ 330F Module is that all the components are designed to work with the existing power lines. KQ 330F Modules are widely available, and the range of devices that are available provide a variety of applications that can be achieved using simple plug-in or wire-in modules.

### 5. BLOCK DIAGRAM OF EMBEDDED POWER LINE COMMUNICATION SYSTEM

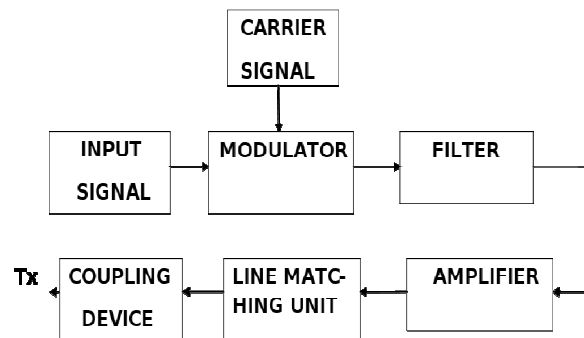

Figure.1. EPLCS TRANSMITTER

The basic block diagram of the transmitter for data communication using power line carrier communication system is shown in Fig. 1 .The existing electrical layout is used to transmit the data or command for the proposed control system from one point towards other without any interference in the electrical signal within the same house. The system can be used to transmit a data signal in the frequency range of 3 KHz to 148.5 KHz. Since we are using a PLC which is a data communication device. The data code generated is modulated using any of the popular modulation techniques and after that it is fed to the amplifier. Later the signal enters to the power line through the interface circuit that includes a resistor and a capacitor i.e. Line matching unit and coupling device. The coupling capacitor is used so that we can couple the 5V signal to the 230V signal so that the circuit will not get disturbed.

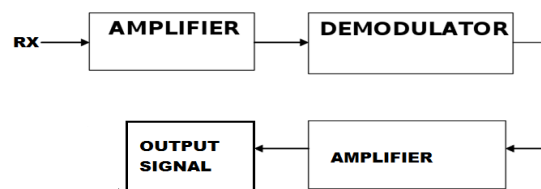

Figure.2. EPLCS Receiver

The basic block diagram of the receiver for data communication using power line carrier communication system is shown in Fig. 2.The data that is received is first fed to the amplifier to strengthen the weak signal and then it is given to demodulator then we get the original message signal.

### 6. IMPLEMENTED EPLCS

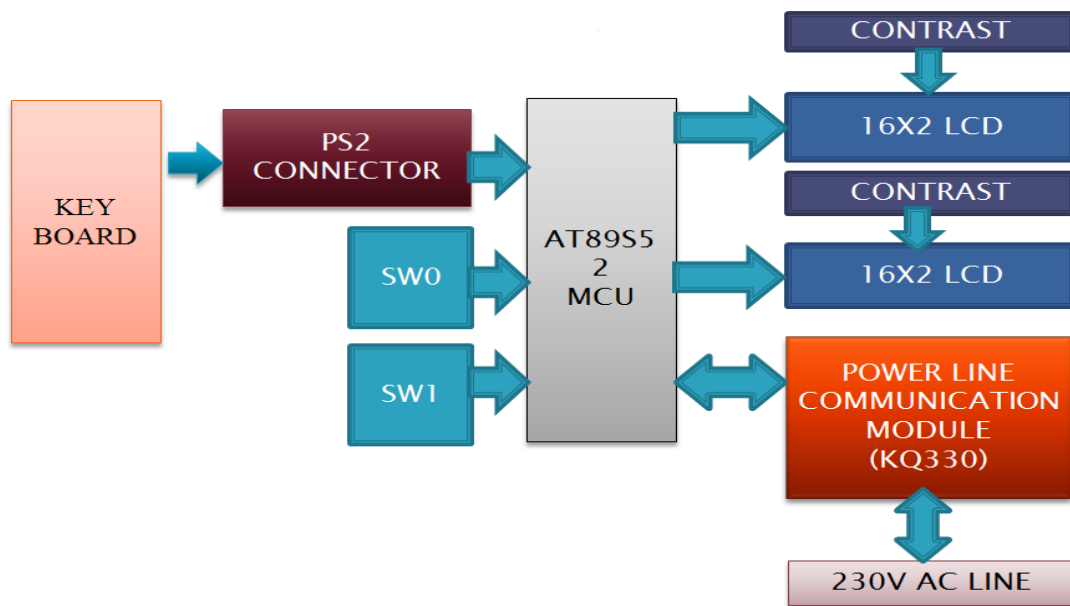
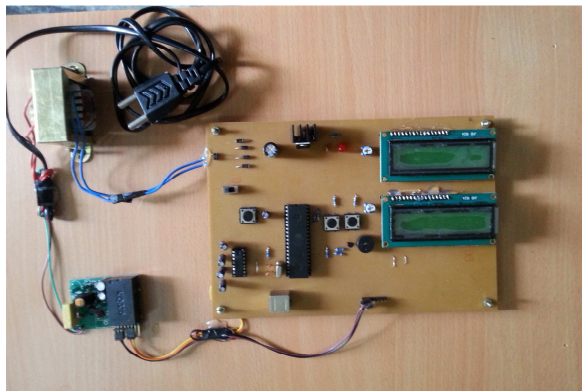

Figure.3. Block Diagram of Embedded Power Line Communication Transceiver Module (EPLCS)

In this project the data is being transferred over AC line from PC communication port, which is encoded and decoded by PLC chips. In this the source information is generated by a key board and this will be sent to destination through kq330 (power line module) communication. The receiving system will check the data and displays on the LCD. The power line module communication used here are KQ330 Transmitter/Receiver, The transmitter stage must be carefully designed to take digital signals from the MCU, filter them to eliminate out of band emissions and drive the low impedance of the AC power line. In receiver section of the power line module receive the data through the power line communication module (KQ330) and send to the receiver section of the microcontroller unit and display on the LCD.

## 7. TRANSCEIVER MODULE CIRCUIT



### 7.1. Working:

This circuit contains key board, LCD display and microcontroller both side. We send the data using

program prepared in Embedded C through serial port. This serial port is connected to power line communication module (PLM). This PLM is assigned supply of 230V mains. On the receiver side, same circuit is connected to power line on the same phase. This circuit receives data which is connected to AT89C52 microcontroller. Whenever you press switch0, on the LCD screen it asks to enter the data. After entering the data you have to press switch1 then the microcontroller reads the data and transmits to the modem. This modem injects the data in power line. At the receiver side same modem is used to decode the data and it is fed to microcontroller. Finally the message that you entered is displayed on LCD

### 7.2. Transmitting Mode:

In order to transmit the message first you have to plug in the power supply for both transmitter and receiver. At the transmitter circuit on the first LCD it asks to press sw0 (switch0) to type the message



After pressing sw0, you have to enter the message. In this we entered the message "HELLO"

### 8. KQ 330F MODEM



After entering the message you have to press enter button on key board and switch1 (sw1).then it transmits the message

#### 7.3. Receiving Mode:

After pressing switch1 at transmitter, immediately at the receiver side on the 2<sup>nd</sup> LCD it displays the message.

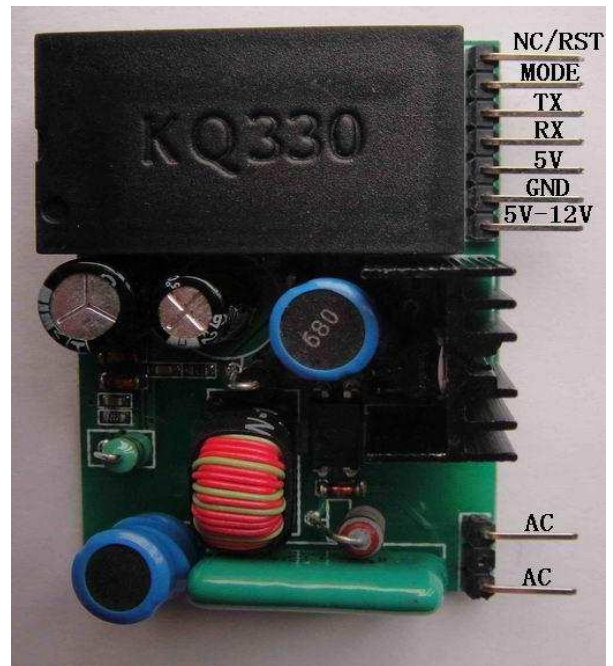

The data given to PLC module will be encoded into a carrier frequency of 120 KHz and modulated with 50Hz AC signal. (Frequency Modulation) .The modulated signal can travel up to 1.5km through a live AC 230V power line. The modulated AC signal is given to this module at AC terminals. Capacitors allows only carrier frequency and blocks 50Hz signals, as  $X_C = 1/2\pi fC$  (Capacitor allows high frequency signal and blocks low frequency signal) Two level capacitor based demodulation is done. Inductors / coils are used to block the high frequency signal, and bypasses the low frequency signals and derives 5V, 2A DC power source required for the module. ( $X_L = 2\pi fL$ . Inductor

blocks high frequency signals and allows low frequency signals)

### 8.1. Operation Principal:

In the design of PLC transceivers modem, channel impedance is important like that other networks. In order to maximum power transfer between the PLC modem and the power line, modem output impedance and the power line input impedance should be matched. Therefore for the modem design, impedance of the power line must be known.

In order to calculate the impedance offered by power line communication modem we have general formula

$$|Z| = 0.005 * f^{0.63}$$

Where

$$|Z| = \text{Impedance}$$

$$f = \text{Carrier frequency}$$

In our experiment we use KQ 330F modem which uses carrier frequency 120 kHz. So the impedance Z is

$$|Z| = 0.005 * (120 * 10^3)^{0.63}$$

Therefore  $|Z| = 8\Omega$ .

However the input (and output) impedance varies in time, with different loads and locations. It can be as low as milli  $\Omega$  and as high as several thousands of  $\Omega$ . So there is a chance of occurring impedance mismatch. Use of filters will stabilize the network.

## 9. APPLICATIONS

- *Monitoring*: measurements on equipment and network elements, AMR and DSM services, etc.
- *Operational services*: remote control, emergency signals, security systems, messaging, etc.
- *Network-management optimization*: minimizing harmful events, such as faults, network maintenance, ancillary services, etc.
- Home and Industrial Automation
- Internet access

## 10. ADVANTAGES

- It's inexpensive
- It uses existing electrical wiring.
- It provides Flexibility & Stability.
- It's easy to install.
- PLC solution is a complementary or alternative solution to traditional fixed line networks, wireless networks.
- Every room of a typical house has several electrical outlets.

## 11. CONCLUSION

Tests in PLC have been carried out in 20 countries in around 1500 residences. The mapping of results has been extremely positive and forecasts a great demand for the system. Power line communication technology is definitely an exciting alternative to connect internet via phone and modem. Though this technology is not commercially available yet, it should be available over other broadband technologies due to relatively low cost of its local loop. Moreover, its high speed will provide internet access, local phone, and long distance service to customers

## REFERENCES

- [1] Power line communication by John Wiley volume 16 issue5
- [2] Broadband is Power: internet access through power line network, IEEE Communications Magazine.
- [3] Hendrik C Ferreira and Olaf Hooijen, —Power Line Communications: An Overview, Transactions of the S.A Institute of Electrical Engineers
- [4] Comm. Eur. Union, “Smart grids technology platform. European technology platform for the electricity networks of the future.” Belgium, EUR 22040, 2006. [Online]. Available: www.smartgrids.eu
- [5] N. Jenkins, J. B. Ekanayake, and C. Strbac, *Distributed Generation*. London, UK: IET Publ., 2010.
- [6] D. Coll-Mayor, M. Paget, and E. Lightner, “Future intelligent power grids: Analysis of the vision in the European Union and the United States,” *Energy Policy*, vol. 354, pp. 2453–2465, 2007.
- [7] S. Galli, A. Scaglione, and Z. Wang, “For the grid and through the grid: The role of power line communications in the smart grid,” *Proc.IEEE*, vol. 99, no. 6, pp. 998–1027, Jun. 2011.
- [8] S. Grenard, O. Devaux, O. Carre, & O. Huet, “Power steering,” *IEEE Power Energy Mag.*, vol. 9, no. 5, pp. 43–51, Sep./Oct. 2011.
- [9] S. Roy, D. Nordell, and S. S. Venkata, “Lines of communication,” *IEEE Power Energy Mag.*, vol. 9, no. 5, pp. 65–73, Sep./Oct. 2011.
- [10] U.S. Dept. Energy, “A systems view of the modern grid: Integrated communications,” Feb. 2007.
- [11] V. C. Gungor and F. C. Lambert, “A survey on communication networks for electric system automation,” *Comput. Netw.* vol. 50, pp. 877–897, 2006.

[12] *IEEE Standard for Broadband over Power Line Networks: Medium Access Control and Physical Layer Specifications*, IEEE Standard 1901–2010, Sep. 2010.

[13] A. Ametani, "A general formulation of impedance and admittance of cables," *IEEE Trans. Power App. Syst.*, vol. PAS-99, no. 3, pp. 902–910, May 1980.

[14] Y. Xiaoxian, Z. Tao, Z. Baohui, N. H. Xu, L. Changxin, and T. Lixi, "Investigation of transmission properties on 10-kV medium-voltage

Power lines—Part II: Path loss," *IEEE Trans. Power Del.*, vol. 23, no.4, pp. 1886–1895, Oct. 2008.



**M.SREEJA**, Student of B.Tech. IV year, Electronics and Communication Engineering, Yogananda Institute of Technology and Science [Y.I.T.S], Tirupathi, A.P, India.



**K.DIVYA**, Student of B.Tech. IV year, Electronics and Communication Engineering, Yogananda Institute of Technology and Science [Y.I.T.S], Tirupathi, A.P, India.

## AUTHORS



**S.Venkatesulu** pursuing his PhD in the faculty of Electronics and Communication Engineering from JNTUA, his received bachelor of technology degree in Electronics and communication engineering branch from JNTUH. Master of technology in embedded system branch from JNTUH. His Interest includes embedded system, antenna design, and electromagnetic radiations.



**G.JEEVAN KUMAR**, Student of B.Tech. IV year, Electronics and Communication Engineering, Yogananda Institute of Technology and Science [Y.I.T.S], Tirupathi, A.P, India.



**L.HEMASUNDAR**, Student of B.Tech. IV year, Electronics and Communication Engineering, Yogananda Institute of Technology and Science [Y.I.T.S], Tirupathi, A.P, India.



**M.BHOGENDRANATH**, Student of B.Tech. IV year, Electronics and Communication Engineering, Yogananda Institute of Technology and Science [Y.I.T.S], Tirupathi, A.P, India.